

INSTRUCTION OF ELEVATOR BASKET (FOR WALL MOUNTED CABINET)

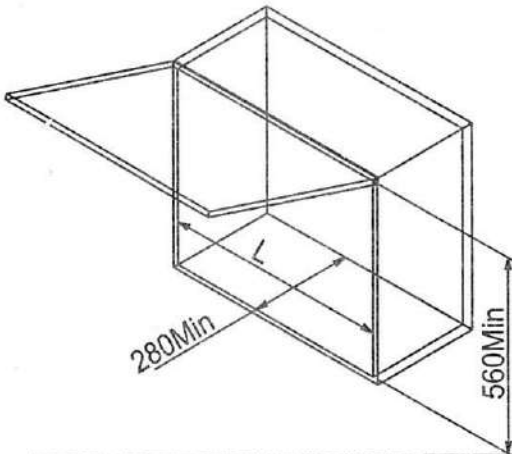

1. One, selection of product specifications and models
Required dimensions of cabinet : 16mm ~ 18mm

A. Upturn door structure



B. Double-door structure

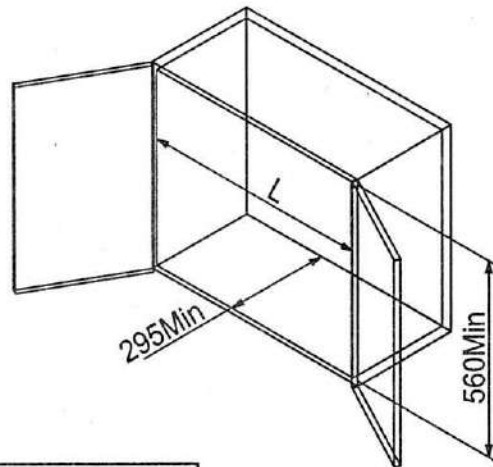

| Cabinet width | Clear width "L" (mm) | Model of lifting cabinet |
|---------------|----------------------|--------------------------|
| 600 Cabinet | 560~564 | A08A/B-600 |
| 700 Cabinet | 660~664 | A08A/B-700 |
| 750 Cabinet | 710~714 | A08A/B-750 |
| 800 Cabinet | 760~764 | A08A/B-800 |
| 900 Cabinet | 860~864 | A08A/B-900 |

2. Fixing steps

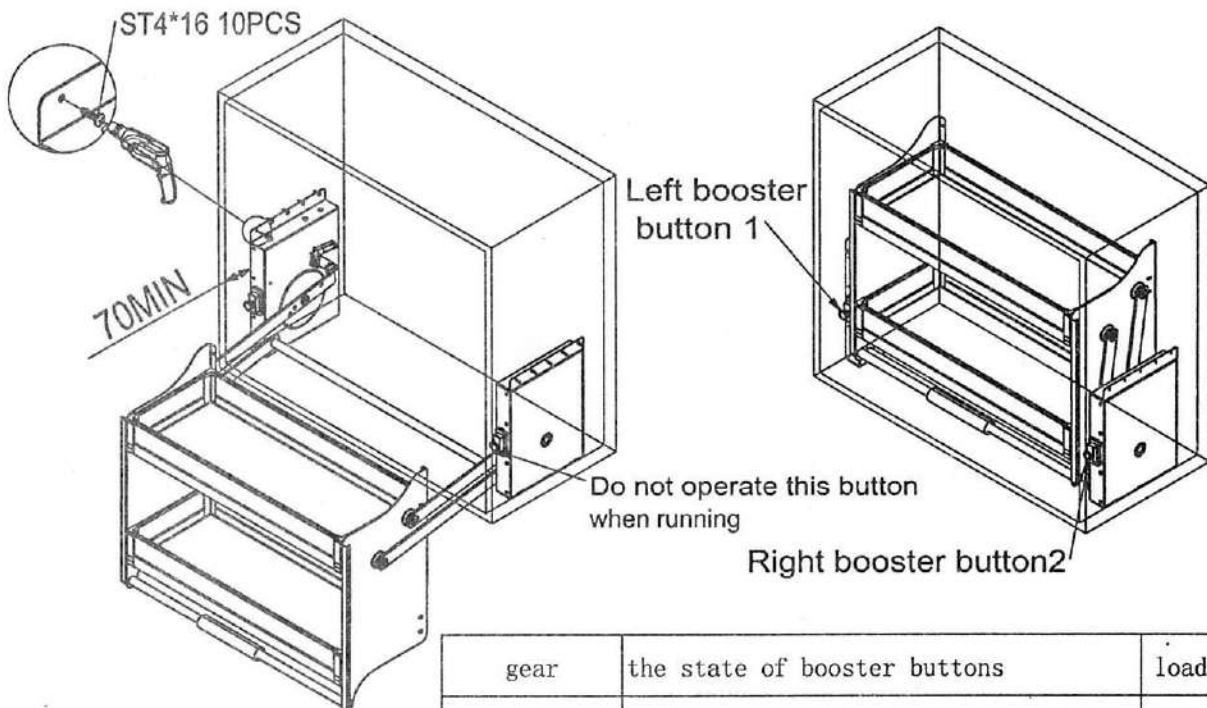

| gear | the state of booster buttons | loaded weight |
|-------------|---|---------------|
| slot | both booster buttons are pressed in | 0~2kg |
| first gear | Pull out the left button 1 and press in the right button 2. | 2~5kg |
| second gear | Press the left button 1 and pull out the right button 2 | 5~7kg |
| third gear | Pull out both buttons | 7~12kg |